

Vernier Caliper

SERIES 531 — with Thumb Clamp

FEATURES

- The slider moves only when the spring loaded thumb clamp is depressed.
- Can measure OD, ID, depth, and steps
- Supplied with vinyl holster in fitted carton.

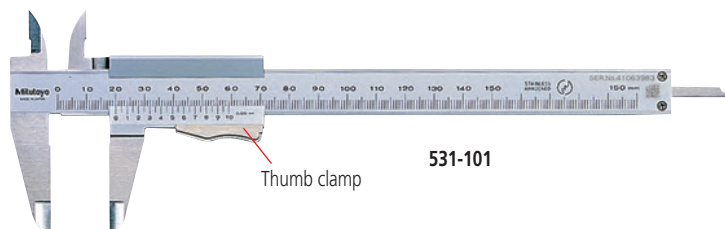

SPECIFICATIONS

Metric

| Range | Order No. | Accuracy | Graduation | Remarks |
|-----------|----------------|----------|------------|---------|
| 0 - 150mm | 531-101 | ±0.05mm | 0.05mm | — |
| 0 - 200mm | 531-102 | ±0.05mm | 0.05mm | — |
| 0 - 300mm | 531-103 | ±0.08mm | 0.05mm | — |

Metric/Inch with metric/inch dual scale

| Range | Order No. | Accuracy | Graduation | | Remarks |
|---------------------|----------------|----------|-------------|-------------|-------------------------------|
| | | | Lower Scale | Upper Scale | |
| 0 - 150mm / 0 - 6" | 531-122 | ±0.05mm | 0.05mm | 1/128" | with inch/mm conversion label |
| 0 - 150mm / 0 - 6" | 531-128 | ±0.03mm | 0.02mm | .001" | High accuracy model |
| 0 - 200mm / 0 - 8" | 531-108 | ±0.05mm | 0.05mm | 1/128" | — |
| 0 - 200mm / 0 - 8" | 531-129 | ±0.03mm | 0.02mm | .001" | High accuracy model |
| 0 - 300mm / 0 - 12" | 531-109 | ±0.08mm | 0.05mm | 1/128" | — |
| 0 - 300mm / 0 - 12" | 531-112 | ±0.04mm | 0.02mm | .001" | High accuracy model |

DIMENSIONS AND MASS

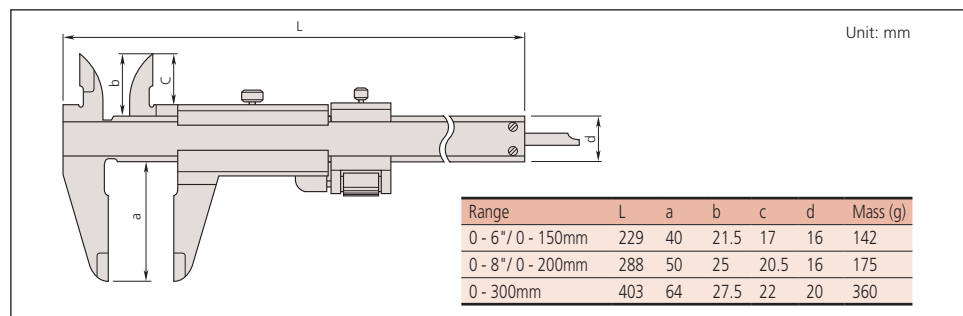

"Quadri" (4 way) Measurement Measurement Applications

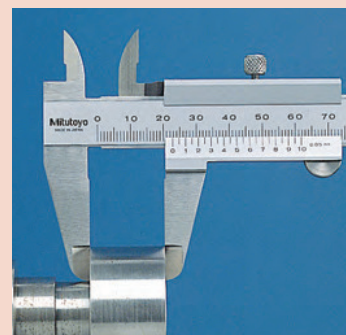

OD measurement

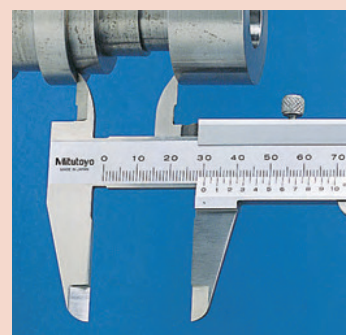

ID measurement

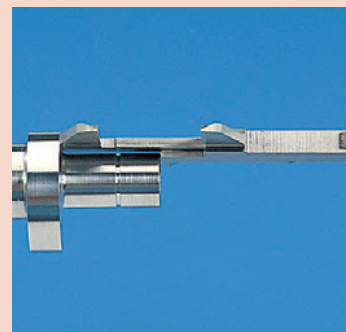

Step measurement

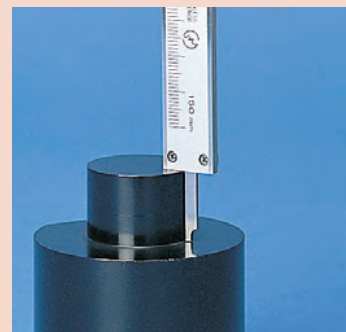

Depth measurement